

### Neptune NTU 1000 E AFP

Touchless dispenser for skin care and hygiene products, stainless steel, 1000 ml, for use with disposable pumps and bottles, lockable

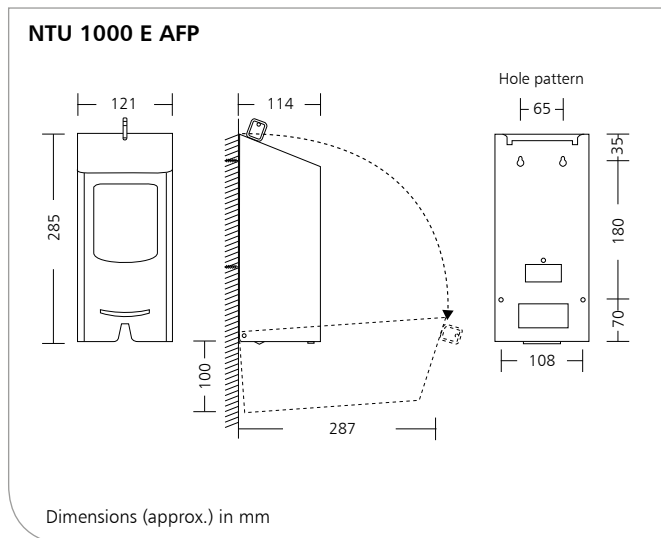

#### Product characteristics

- ▶ Stainless steel with Anti-Fingerprint-Coating
- ▶ Uses various pumps (Ø 38 mm / 45 mm) e.g. liquids, lotions, gel, alco-foam, foam soap, grit, spray, shower from 0.25 to 2.0 ml/stroke
- ▶ Uses a 1 litre bottle
- ▶ Lockable

#### Interesting information

References: ▶ Nursing homes, hospitals, laboratories, large kitchens, food industry, industry, shopping centers, gastronomy and hotels, airports, penal institutions, schools, sport facilities, administrations

#### Areas of Application:

- ▶ Washrooms, toilets, baths, care and medical rooms, kitchens, production sites, offices

#### Technical Data

|                |  |
|----------------|--|
| Housing:       | Stainless steel, brushed with Anti-Fingerprint-Coating           |
| Window:        | Plastic, clear   |
| Dosing pump:   | Liquids, lotions, gel, alco-foam, foam soap, grit, spray, shower |
| Dosages:       | 0.25 ml to 2.0 ml depending on pump and product                  |
| Lock:          | Plastic (Anti-Vandalism-Function)                                |
| Key:           | Plastic  |
| Batteries:     | 4 C-Cells, 1.5 Volt  |
| Wall mounting: | With three screws and plugs                                      |
| Bottle:        | Disposable collapsible bottle, soft flexible plastic, 1000 ml    |

#### Description for tender

**NTU 1000 E AFP** **Art. No. 1419768**

... pcs. Dispenser for soap and disinfectants, 1000 ml, brushed stainless steel, with Anti-Fingerprint-Coating, touchless, approximation sensor, with visual signal for operational readiness, window for fill level control, disposable pump and disposable collapsible bottle, not autoclavable, not dishwasher safe, housing with sloped lid on the roof to prevent items from being placed on the dispenser, with safety catch  
Dimensions: W 121 x H 285 x D 114 mm

Product: **OPHARDT Neptune™**  
Manufacturer: OPHARDT HYGIENE-TECHNIK GmbH + Co. KG

Subject to technical modifications.  
Tests are required before new filling materials are used!



OPHARDT HYGIENE-TECHNIK GmbH + Co. KG  
Lindenau 27 | 47661 Issum | Germany  
Tel.: +49 (0) 28 35 18-10 | Fax +49 (0) 28 35 18-77  
planer@ophardt.com | www.ophardt.com