

Neptune NMU 1000 E AFP

Dispenser for skin care and hygiene products, stainless steel, 1000 ml, for use with disposable pumps and bottles, lockable

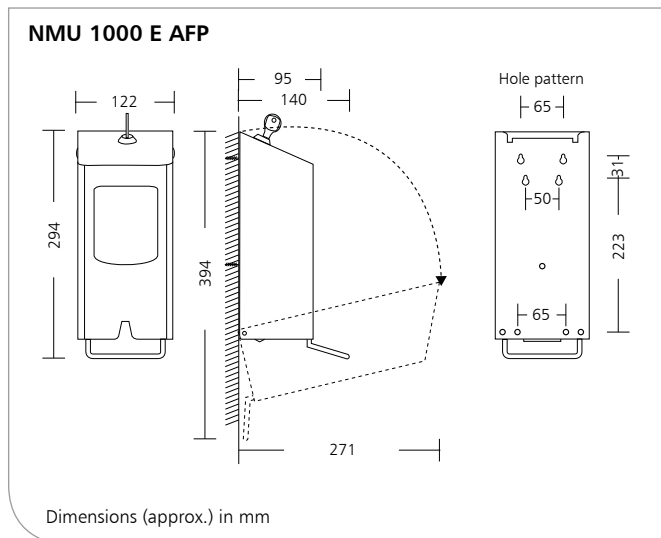

Product characteristics

- ▶ Stainless steel with Anti-Fingerprint-Coating
- ▶ Uses various pumps (Ø 38 mm / 45 mm) e.g. liquids, lotions, gel, alco-foam, foam soap, grit, spray, shower from 0.25 to 2.0 ml/stroke
- ▶ Uses a 1 litre bottle
- ▶ Lockable

Interesting information

References: ▶ Nursing homes, hospitals, laboratories, large kitchens, food industry, industry, shopping centers, gastronomy and hotels, airports, penal institutions, schools, sport facilities, administrations

Areas of Application: ▶ Washrooms, toilets, baths, care and medical rooms, kitchens, production sites, offices

Technical Data

Housing:	Stainless steel, brushed with Anti-Fingerprint-Coating
Window:	Plastic, clear
Dosing pump:	Liquids, lotions, gel, alco-foam, foam soap, grit, spray, shower
Dosages:	0.25 ml to 2.0 ml depending on pump and product
Lock:	Metal
Key:	Metal
Lever:	Stainless steel
Wall mounting:	With three screws and plugs
Bottle:	Disposable collapsible bottle, soft flexible plastic, 1000 ml

Description for tender

... pcs. **NMU 1000 E AFP** **Art. No. 3401061**
 Dispenser for soap and disinfectants, 1000 ml, brushed stainless steel, with Anti-Fingerprint-Coating, stainless steel operating lever, window for fill level control, disposable pump and disposable collapsible bottle, not autoclavable, not dishwasher safe, housing with sloped lid on the roof to prevent items from being placed on the dispenser, with safety catch
 Dimensions: W 122 x H 294 x D 140 mm

Product: **OPHARDT Neptune™**
 Manufacturer: OPHARDT HYGIENE-TECHNIK GmbH + Co. KG

Subject to technical modifications.
 Tests are required before new filling materials are used!



OPHARDT HYGIENE-TECHNIK GmbH + Co. KG
 Lindenau 27 | 47661 Issum | Germany
 Tel.: +49 (0) 28 35 18-10 | Fax +49 (0) 28 35 18-77
 planer@ophardt.com | www.ophardt.com